

E1671 rev.2.00 - 18/09/2020



Adjustable opening valves
VL-2R

GENERAL WARNINGS



- Each manual, including this one, is an integral part of the ESA catalog.
- Each manual may contain errors or give rise to interpretative doubts. ESA invites you to report any interpretative errors or doubts but will not be able to consider such occurrences as the cause of any disputes.
- This manual and all its parts (logos, texts, photos, tables, graphics, etc...) cannot be reproduced or modified in whole or in part without the written consent of ESA.
- The technical information relating to the design, installation, regulation and operation of the combustion plant intended to host ESA products must be previously shared with ESA. Failing this, ESA declines all responsibility in relation to damage to things and people deriving from improper use of the products.
- In general, a combustion plant is not designed for oven drying refractories. In case of this use, ESA declines any responsibility in this regard.
- The performance of the products indicated in each manual is the result of tests conducted using ESA equipment at our Research and Development Center, under certain operating conditions. These performances cannot be guaranteed using other equipment or outside the aforementioned conditions.
- The design, installation, adjustment and operation of a combustion plant require compliance with all applicable safety standards and regulations. ESA declines any responsibility in relation to its products, if used in plants or in circumstances in which the regulations in force in the place of use are not respected.
- All installation, maintenance, ignition and calibration operations must be carried out by qualified personnel in compliance with all the points indicated in this manual. The indications given in this document do not exempt the customer/user from observing the general and specific legal provisions.
- All personnel responsible for checking and operating the device must be informed of the contents of this manual and must strictly follow its instructions. The operator must wear suitable clothing and PPE according to the legal requirements, respecting the general safety and risk prevention rules. If clarifications, additional information or training are required, contact the ESA sales offices.
- ESA reserves the right to modify the technical characteristics of the products by updating the relative manual at any time and without notice. By consulting the website **www.esapyronics.com** it is possible to download the manuals updated to the latest revision in Italian and English.

LOGISTICS AND DISPOSAL



- **Transport:** protect the equipment from shocks, vibrations, atmospheric agents, etc... Upon receipt of the product, check the labeling in accordance with the order and promptly notify any discrepancies and/or transport damage.
- **Storage:** store the product in a suitable place, according to the product specifications.
- **Packaging:** the material used must be disposed of according to local regulations.
- **Disposal:** comply with local legislation on this matter.

CERTIFICATIONS



CE according to Annex II No. 1B of the Machinery Directive **2006/42/EC**: the valve implemented is considered a partly completed machine, for which the declaration of incorporation is available.



EAC for the Eurasian market (Russia, Belarus and Kazakhstan).

- ESA adopts the Quality System certified by DNV GL in compliance with the **UNI EN ISO 9001** standard.
- ESA adopts the Code of Ethics and Behavior pursuant to Legislative Decree **231/01**.
- ESA products are designed, manufactured and controlled in compliance with the Directives/Regulations, in particular **UNI EN 746-2** "Industrial thermal process equipment - Part 2: Safety requirements for combustion and for the handling and treatment of fuels" harmonized with the Machinery Directive **2006/42/EC**.

DESCRIPTION

The VL-2R series identifies a particular model of motorized valves, with an adjustable opening suitable for regulating the flow rate of fluids in low pressure ducts. The flow is adjusted by acting on the primary adjustment shaft by means of an electric servo control of the ESA SERIO series; on the front there is a graduated index that identifies the OPEN/CLOSED position of the valve. By means of the secondary adjustment shaft it is possible to vary the passage of the valve in order to allow the operator a more accurate regulation of the flow rate.

FEATURES

Technical features

Fluids:	Non aggressive gases according to EN437
Maximum working pressure:	450 [mbar] @ 60 [°C] 180 [°WC] @ 140 [°F]
Maximum fluid temperature:	60 [°C] 140 [°F]
Operating temperature:	-20 ÷ +60 [°C] -4 ÷ +140 [°F]
Storage temperature:	0 ÷ +25 [°C] 32 ÷ 77 [°F]
Leakage with closed valve:	< 1%
Available sizes:	from Rp 1/2 "to Rp 2" according to ISO 7/1 from DN65 to DN150 flanged to be welded, NPT thread on request
Rotation angle:	0-90°
Valve body base connection:	ISO5211 (F.05/F.07)

Construction features

Valve body:	Aluminum
Shaft:	OT58
Adjustment screw:	AISI303 in option AISI316
Actuator support plate:	AISI304
Actuator coupling rod:	C.S. galvanized
Valve control lever:	AISI304+Fe360 galvanized
Shaft tightness:	"O" ring (special seals on request)

Electric motorizations

Coupling with valve:	direct (D) or with levers (L)
Off/min/max management:	ESA SERIO TPF E7301
3-point floating management:	ESA SERIO FLT E7302
Proportional management:	ESA SERIO PRP E7303

Accessories

Connection flange:	PF, PFP, PFF and PSP series - E5701
Pressure outlet:	ESA pressure taps - E5712

GALLERY



F167101

VL-2R-D



VL-2R-L

F167102

FLOW CHART FULLY OPEN VALVE

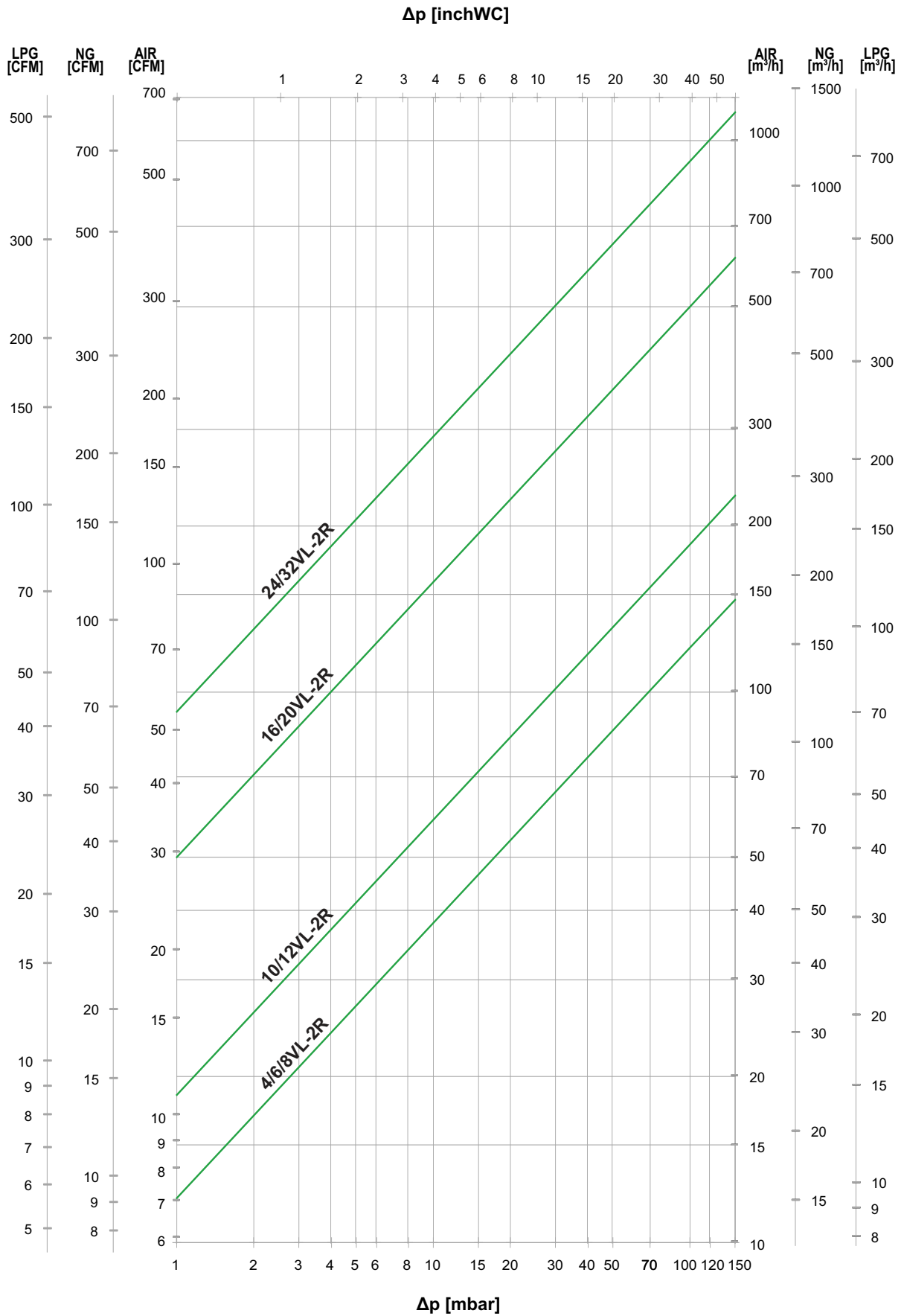

T=0 [°C] e Ps=1013 [mbar]

G1671101

VELOCITY GRAPH

To correctly size noise and pressure drops, the maximum recommended speed of the flow inside a pipe must be limited to 30 [m/s] or 5920 [ft/min] (ESA recommends <20 [m/s] or 3950 [ft/min]). The velocities are calculated taking into account carbon steel pipes according to the standard EN 10255 Medium Series. Different pipe thickness will correspondingly result in different flow rates.

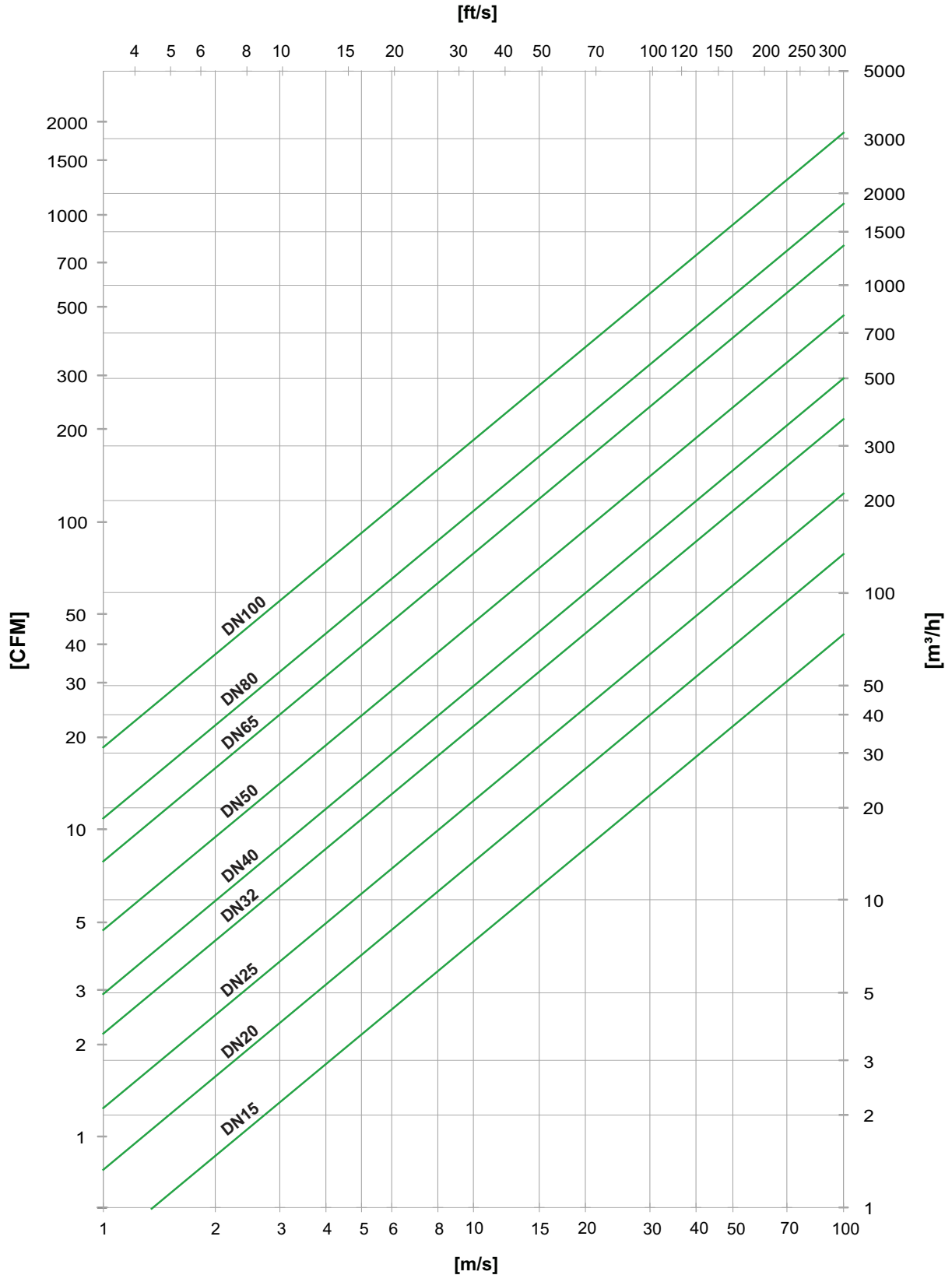

G1671102

CALCULATION OF THE FLOW OF A GAS OTHER THAN AIR

The flow rate diagram refers to the three main fluids used in applications relating to combustion plants (air, natural gas and LPG).

To calculate the valve flow rate, relative to a gas other than those listed above, starting from the air flow rate resulting from the graph, the following formula can be used:

$$Q_{\text{gas}} = \sqrt{\frac{1.2928}{\rho_{\text{gas}}}} * Q_{\text{air}}$$

T= 0 [°C] and Ps 1013 [mbar]

knowing the density of the gas whose flow rate is to be calculated. Typical densities of some common gases can be found below:

Gas type	ρ_{gas} @0 [°C] [Kg/m ³]	MM molecular mass [-]
Air	1.2928	28.96
Natural gas	0.78	18.2
LPG (95% propane)	2.01	45.50
Nitrogen	1.25	28.01
BFG (60% N ₂ , 24% CO, 12% CO ₂ , 4% H ₂)	1.29	28.89
COG (50% H ₂ 30% CH ₄ 3% C _n H _m 7% CO 3% CO ₂ 7% N ₂)	0.553	12.39
CO ₂	1.976	44.01
Exhausted from NG (3% O ₂)	1.243	27.85
Exhausted from LPG (3% O ₂)	1.271	28.47

EG.1

To calculate the flow rate of a 16VL-2R valve at 10 [mbar] of Δp , used for natural gas, the air flow rate is obtained on the graph (specifically, it reads about 160 [m³/h]).

Using the above formula:

$$Q_{\text{gas}} = \sqrt{\frac{1.2928}{0.78}} * 160 = 206 \text{ [m}^3\text{/h]}$$

This simplified formula calculates a volumetric flow rate in [m³/h]; to have a reference in [Nm³/h] the following parameters must be taken into consideration:

- P_{in} input pressure
- Fluid temperature
- Altitude of the application (this value changes the P_{atm})

The following exercise explains the conversion process between [m³/h] and [Nm³/h].

EG.2

To calculate the flow rate of a 32VL-2R valve at 10 [mbar] of Δp with an inlet pressure of 80 [mbar], used for air at Tref = 40 [°C], the air flow rate is obtained on the graph in [m³/h]:

$$Q_{\text{air } 0 \text{ [°C]}} = 285 \text{ [m}^3\text{/h]}$$

Now it is necessary to transform [m³/h] into [Nm³/h], using the following procedure.

Obtain the density of the gas at the operating temperature and pressure with the following formula:

$$\rho_{\text{air } [40 \text{ °C}]} = \frac{P_{\text{atm}} + P_{\text{in}}}{\left(\frac{8314}{\text{MM}}\right) * T \text{ [°K]}}$$

CALCULATION OF THE FLOW OF A GAS OTHER THAN AIR

where is it:

- P_{atm} atmospheric pressure at a given altitude.
- P_{in} pressure at the valve inlet.
- MM molecular mass of the gas used.
- T temperature in degrees Kelvin of the gas.

which, with the project data it results:

$$\rho_{\text{air}} [40\text{ }^{\circ}\text{C}] = \frac{101325 + 8000}{\left(\frac{8314}{28.96}\right) * 323.15} = 1.171 \text{ [kg/m}^3\text{]}$$

Now we calculate the flow rate with the following formula:

$$Q_{[\text{Nm}^3/\text{h}]} = \frac{\rho_{\text{air}} [40\text{ }^{\circ}\text{C}]}{\rho_{\text{air}} [0\text{ }^{\circ}\text{C}]} * Q_{[\text{m}^3/\text{h}]}$$

Which with the project data results:

$$Q_{[\text{Nm}^3/\text{h}]} = \frac{1.171}{1.2928} * 285 = 258.1 \text{ [Nm}^3/\text{h}]$$

Select the size of a valve starting from a plant data with flow rate in [Nm³/h], the reverse procedure is carried out, obtaining the density at a given temperature and using the inverse formula with respect to the previous one:

$$Q_{[\text{m}^3/\text{h}]} = \frac{\rho_{\text{gas } 0\text{ }^{\circ}\text{C}}}{\rho_{\text{gas Tref}}} * Q_{[\text{Nm}^3/\text{h}]}$$

VALVE SIZING

Since the valve has a flow regulation function:

- select the diameter of the pipe according to the maximum speed to be respected (<20[m/s]).
- onsidering that, for optimal valve regulation, the Δp must be approximately 25 ÷ 30% of the valve inlet is a known variable, calculate the Δp of the valve according to the following formula:

$$\Delta p_{100\%} = \frac{a * p_2}{(1 - a)}$$

EG. Select an air valve with p₂= 45 [mbar] and flow rate V= 100 [Nm³/h]. In order not to exceed the recommended flow rate, DN50 pipes can be used.

The pressure drop will be:

$$\Delta p_{100\%} = \frac{0.3 * 45[\text{mbar}]}{(1 - 0.3)} = 19.3[\text{mbar}]$$

From the diagram of the VL-2R valves it appears that the valve that guarantees the required flow rate is DN50. Given the diameter of the pipes, the valve will be installed in the pipe without reductions. The inlet pressure to the pipeline must therefore be:

$$p_1 = \Delta p_{100\%} + p_2 = 64.3[\text{mbar}]$$

This data, added to other line pressure losses possibly present upstream of the valve, will be used for the correct sizing of the combustion fan.

WARNINGS

The VL-2R series valves are regulating and not safety devices, the tightness is guaranteed only for leaks towards the outside, they are not suitable for interception of fuels and are not part of the protection system according to EN746-2.

Any modification or repair carried out by unauthorized personnel compromises the safety of the application and automatically invalidates the general warranty conditions. For correct use, observe the following warnings.



- Make sure that all system features are compatible with the valve specifications: hydraulic connections, type of fluid, operating pressure, flow rate, temperature range, voltage, etc...
- Avoid excessive amounts of sealant in case of threaded connections, which could enter the valve.
- Before proceeding with any installation or service operation, close the upstream air/gas flow and disconnect the power supply.
- If the valve is equipped with an actuator, respect the "Warnings" specified in the technical documentation of the same.
- If the valve accidentally falls, it can suffer permanent damage; in this case it is mandatory to replace the equipment.
- Avoid water hammer.
- Any dirt chips, welding residues or sealing materials must not come into contact with the internal parts of the valve.
- It is good practice to install a filter upstream of the supply piping.
- Do not damage the sealing surfaces of the flanges.



- To avoid the risk of burns and electrocution, the operator must not come into contact with electrical devices.
- Operate on the actuator and on the connected devices only in the absence of power supply.
- Check that the utilities do not have an absorption higher than the maximum capacity of the limit switch contacts or of the feedback signal.
- In order not to damage the electric actuator, do not manually rotate the shaft, let alone force its movement by acting on the lever or using tools.



- Work on the actuator and on the connected devices paying attention to the movement of the return levers between the valve shaft and the servomotor.

VL-2R-D / VL-2R-L INSTALLATION

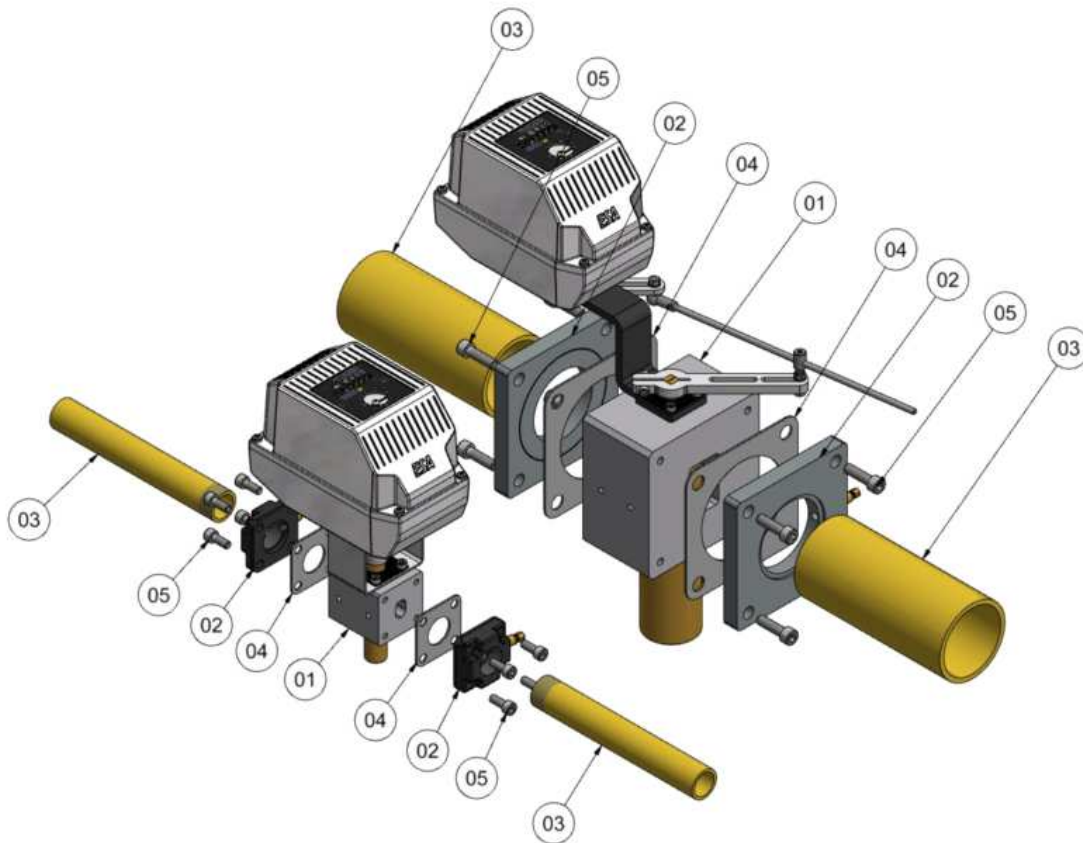

D1671101

The VL-2R series valves are equipped with coupling flanges and seals suitable for the type of valve and application.

The valve can be installed in a horizontal or vertical position, not upside down, respecting a straight section of upstream and downstream piping of at least 2xDN.

Maintain a distance from the surrounding obstructions that allows free air circulation and proper maintenance. In the case of installing contiguous valves, check that there is no interference between the levers during their movement.

For the installation of the VL-2R valves, also refer to the technical documentation of the actuator.

Connect the pipes (**pos.03**) to the flanges (**pos.02**). Depending on the version, the connection can be welded or threaded:

- A** - For threaded connections, use thread sealing paste, taking care not to introduce excess sealant inside the valve.
- For welded connections, perform a tight seal and eliminate any residues.

- B** Check the correct alignment of the pipes (**pos.03**) and the spacing between the flanges (**pos.02**), in order to avoid exerting tension on the pipes during the tightening phase.

- C** Make sure that there are no foreign bodies inside the valve (**pos.01**) or in the pipes (**pos.03**) before carrying out the assembly.

- D** Sert the bolts (**pos.05**) in the fixing holes of one of the two flanges (**pos.02**) and position the valve (**pos.01**) and the first gasket (**pos.04**); then mount flanges, gaskets and screws on the opposite side. Use only suitable tools and avoid excessive tightening.

- E** For the installation of the threaded version, do not screw the valve on the pipe by levering the adjustment stem.

- F** After assembly, check the correct opening and closing movement of the valve and return the adjustment screw to the closed position.

- G** The correct installation and sealing of the valve and its gaskets towards the outside must be performed through a functional test at a test pressure 1.1 times the working pressure.

SEQUENCE OF SCREWS TIGHTENING ON ATTACHMENT FLANGES

Tighten the bolts and nuts in a crisscross pattern, using a minimum of three tightening passes and maximum bolt stress as defined in the tables below.

STEP 1: Torque up to a maximum of 30% of the final torque value according to the torque sequence. Make sure the gasket is compressed evenly.

STEP 2: Torque up to a maximum of 60% of the final torque value.

STEP 3: Torque at final torque value (100%).

After completing the three basic torque steps, retighten the nuts at least once using the final torque crosswise until no further nut rotation is observed.

THREADED FLANGES

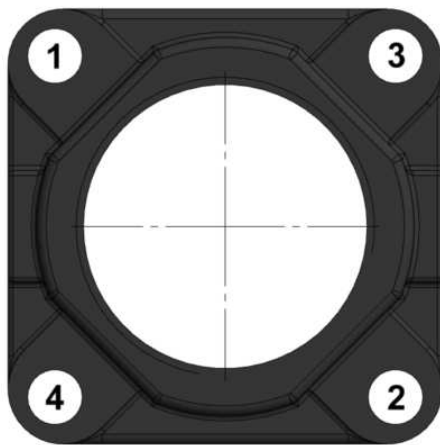

WELDING FLANGES

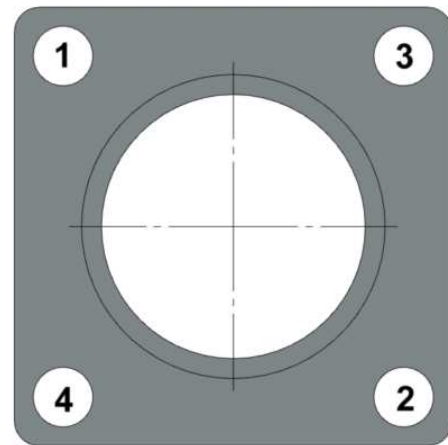

D1671I02

4 bolt flange: 1,2,3,4

DN [mm]	PN 0.5	
	[Nm]	[Ft/lbs]
15/20/25	30	22
32/40/50	50	37
65/80/100	50	37
125/150	70	52

VL-2R-D & VL-2R-L REGULATION AND CALIBRATION

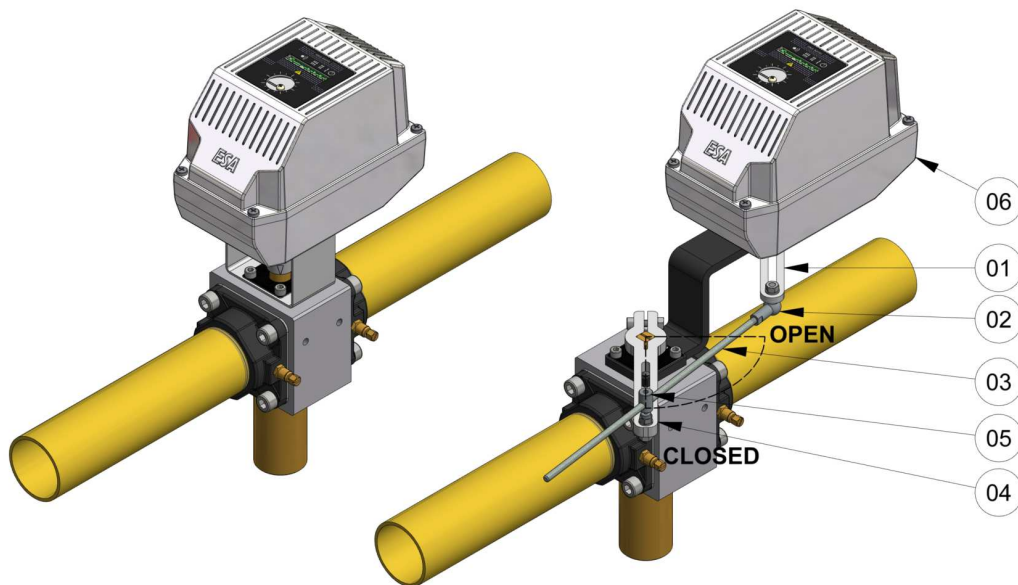

D1671103

The VL-2R valves are supplied with a preliminary calibration with $0 \pm 90^\circ$ adjustment. During the adjustment phase, monitor the pressure and flow rate parameters of the pipeline using suitable instruments (calibrated flanges, differential pressure gauges, etc...).

- The VL-2R-D are adjusted by acting on the actuator stroke, referring to the technical documentation of the same.
- The VL-2R-L are calibrated by acting on the levers and return joints: acting on the actuator stroke, in particular in the floating and proportional versions, would reduce its accuracy. If there is an ESA SERIO servomotor, proceed as follows:

- A** Open the actuator cover to access the local control station. Activate the "Manual" mode using the specific selector, disabling the remote control.
- B** Command the actuator to close, so that the valve closes completely.
- C** Loosen the rod locking dowel located on the joint (**pos. 05**). Adjust the minimum opening by sliding the rod (**pos. 03**) into the joint and move the valve using the slotted lever (**pos. 04**), until the required flow rate is reached. At the end, tighten the set screw.
- D** Command the actuator so that the valve opens completely.
Check the flow rate between minimum and maximum opening: if the maximum flow rate is reached before the actuator reaches full opening, the valve stroke must be reduced, otherwise it must be increased. The goal can be achieved in two ways:
- E**
 - bring the joint (**pos. 02**) close to the actuator pin (**pos. 06**), making it slide into the slotted lever (**pos. 01**).
 - remove the joint (**pos. 05**) from the pin by sliding it into the slotted lever (**pos. 04**).
- F** Carry out the minimum opening adjustment again as described in point **C**.
Check the new regulation by repeating the operations indicated between points **D** and **E** until the required flow regulation is obtained.
- G** Activate the "automatic" mode using the specific selector, checking that the commands from the control system are consistent with the movement of the actuator.
- H** At the end, close the lid, checking the correct positioning of the gasket and making sure that the electrical conductors do not remain pressed between the lid and the base.
- I** It is recommended to mark the locking positions of the joints on the levers: this maintains the set setting in case of replacement of the actuator.

MAINTENANCE

All maintenance operations, due to the short time and working conditions in which they can be carried out, involve a greater risk of errors and accidents and must therefore be carried out after careful and in-depth analysis of the risks for the operators and for the process, making sure necessary precautions are in place.

Operation	Frequency [months]	Note
Gaskets integrity	12	Check that there are no leaks to the outside with adequate leak detection liquids. In case of replacement, follow the instructions given in the INSTALLATION paragraph.
Bolt tightening	12	6 months in vibration applications.
Valve movement	6	Check that the valve rotates without friction, lubricate if necessary.
Valve calibration	12	Check the pressure and flow rate parameters of the pipeline using suitable instruments (calibrated flanges, differential pressure gauges, etc...). If necessary, repeat the calibration operations.
Throttle valve maintenance	12	Check the condition of the internal elements, clean with a clean cloth and compressed air, taking care not to damage the internal parts.

Component	Useful life [years]	Command cycles
Valve seal control systems	10	250.000
Pressure switches	10	N/A
Burner control device	10	250.000
UV flame sensor / electrodes	10.000 operating hours	
Gas regulators	10	N/A
Solenoid valves	10	250.000
Relief valve	10	N/A
Regulation valve	10	N/A
Regulators	10	N/A
Servomotors	10	N/A

VL-2R-D OVERALL DIMENSIONS

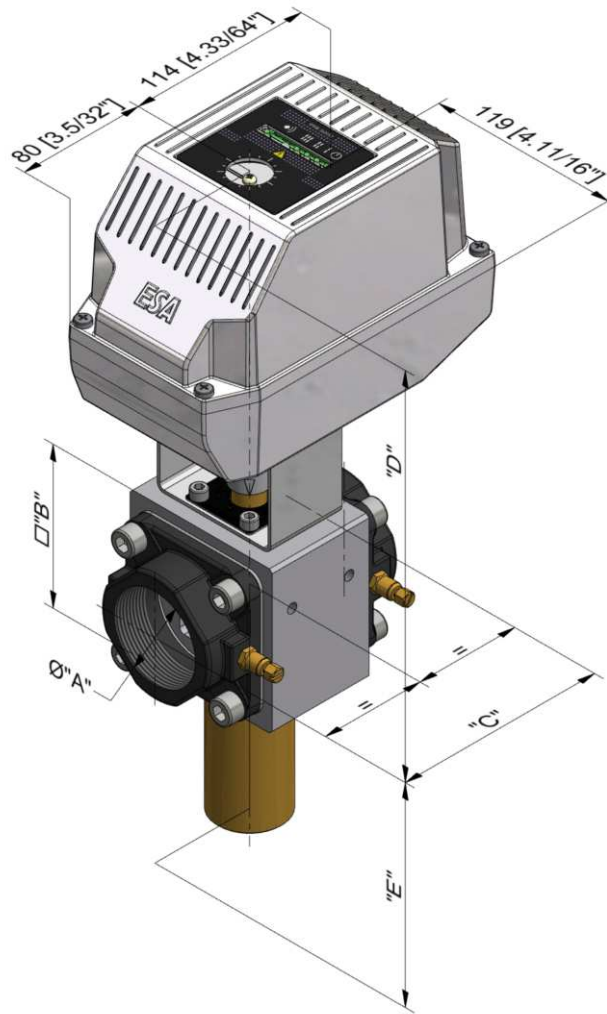

D1671104

Model	DN "A" (*)	Ø "B"		"C"		"D"		"E"		Mass	
		[mm]	[inch]	[mm]	[inch]	[mm]	[inch]	[mm]	[inch]	[Kg]	[lbs]
4VL-2R	Rp 1/2"	60	2.23/64	114	4.31/64	233	9.11/64	74	2.29/32	4.0	8.8
6VL-2R	Rp 3/4"	60	2.23/64	114	4.31/64	233	9.11/64	74	2.29/32	4.0	8.8
8VL-2R	Rp 1"	60	2.23/64	114	4.31/64	233	9.11/64	74	2.29/32	4.0	8.8
10VL-2R	Rp 1.1/4"	80	3.5/32	124	4.7/8	213	8.25/64	119	4.11/16	5.0	11.0
12VL-2R	Rp 1.1/2"	80	3.5/32	124	4.7/8	213	8.25/64	119	4.11/16	5.0	11.0
16VL-2R	Rp 2"	100	3.15/16	133	5.15/64	253	9.61/64	137	5.25/64	7.0	15.4
20VL-2R	DN65	100	3.15/16	107	4.7/32	253	9.61/64	137	5.25/64	7.0	15.4
24VL-2R	DN80	150	5.29/32	130	5.1/8	278	10.15/16	189	7.7/16	15.0	33.0
32VL-2R	DN100	150	5.29/32	130	5.1/8	278	10.15/16	189	7.7/16	15.0	33.0

(*) NPT thread on request up to 16VL-2R

VL-2R-L OVERALL DIMENSIONS

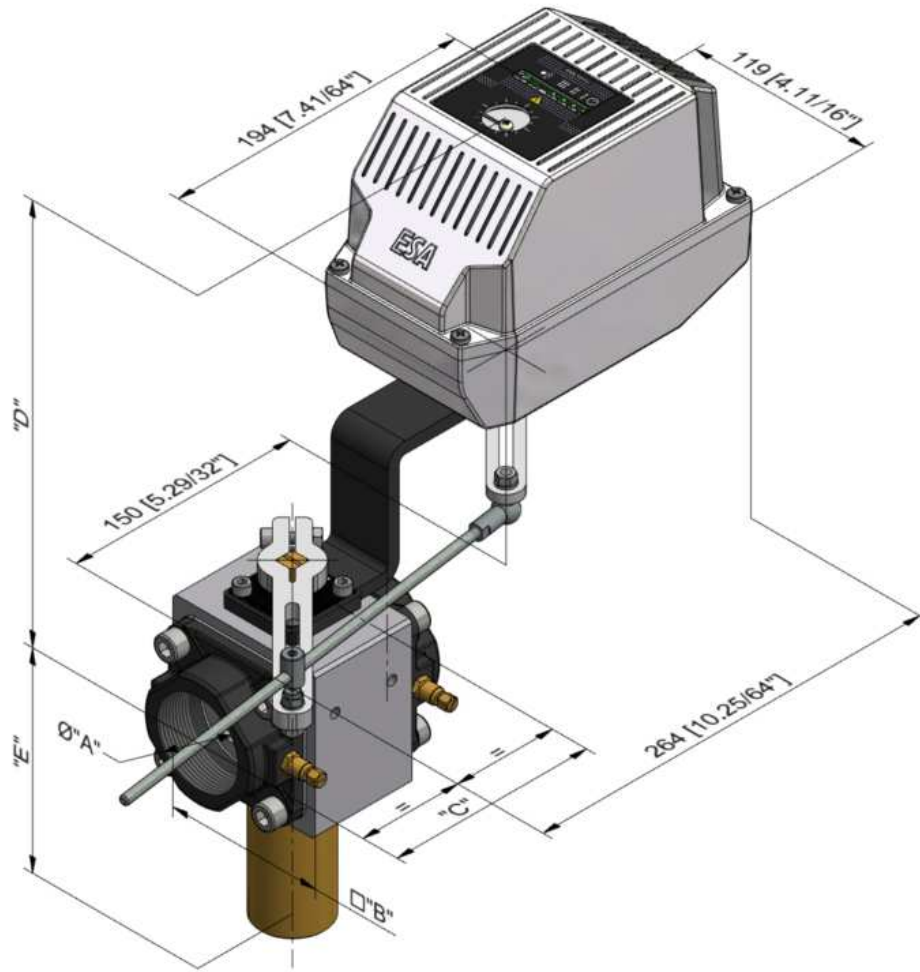

D1671I05

Model	DN "A" (*)	Ø "B"		"C"		"D"		"E"		Mass	
		[mm]	[inch]	[mm]	[inch]	[mm]	[inch]	[mm]	[inch]	[Kg]	[lbs]
4VL-2R	Rp 1/2"	60	2.23/64	114	4.31/64	254	10	74	2.29/32	5.0	11.0
6VL-2R	Rp 3/4"	60	2.23/64	114	4.31/64	254	10	74	2.29/32	5.0	11.0
8VL-2R	Rp 1"	60	2.23/64	114	4.31/64	254	10	74	2.29/32	5.0	11.0
10VL-2R	Rp 1.1/4"	80	3.5/32	124	4.7/8	269	10.19/32	119	4.11/16	6.0	13.2
12VL-2R	Rp 1.1/2"	80	3.5/32	124	4.7/8	269	10.19/32	119	4.11/16	6.0	13.2
16VL-2R	Rp 2"	100	3.15/16	133	5.15/64	274	10.25/32	137	5.25/64	7.3	16.1
20VL-2R	DN65	100	3.15/16	107	4.7/32	274	10.25/32	137	5.25/64	7.3	16.1
24VL-2R	DN80	150	5.29/32	130	5.1/8	300	11.13/16	189	7.7/16	15.0	33.0
32VL-2R	DN100	150	5.29/32	130	5.1/8	300	11.13/16	189	7.7/16	15.0	33.0
48VL-2R	DN150	200	7.7/8	160	6.19/24	324	12.3/4	149	5.55/64	23.0	50.7

(*) NPT thread on request up to 16VL-2R

ORDERING CODE

- VL-2R - - - -

VALVE DIMENSIONS cod. 01

4VL-2R	4
6VL-2R	6
8VL-2R	8
10VL-2R	10
12VL-2R	12
16VL-2R	16
20VL-2R	20
24VL-2R	24
32VL-2R	32
48VL-2R	48(*)

03 ACTUATOR cod.

ESA SERIO off/min/max	TPF
ESA SERIO floating	FLT
ESA SERIO proportional	PRP

04 VALVE CONNECTION cod.

BSP thread	B
NPT thread	N
To weld	W

VALVE CONTROL cod. 02

Direct coupling actuator	D
Actuator coupled with levers	L

05 ACTUATOR PARAMETERS cod.

ESA SERIO-TPF see E7301	...
ESA SERIO-FLT see E7302	...
ESA SERIO-PRP see E7303	...

Note

(*) Only in version L.

(**) The code is must be completed with the voltage of the actuator control solenoid valve.

(***) The code is must be completed with the model of the positioner.

ESA contacts



© 2020 ESA S.p.A. Company under the management and coordination of SIAD S.p.A.
All rights reserved.

The information contained herein is offered for use by technically qualified personnel at their discretion and risk without warranty of any kind.

We regularly update our data, for updated data please visit our web site www.esapyronics.com



ESA Italia (headquarters)

via E. Fermi 40, 24035 Curno (Bergamo), Italy
tel. +39.035.6227411 - esa@esacombustion.it

ESA Belgium

Zoning Industriel, 4ème rue, B-6040 Jumet, Belgium
tel +32.71.256970 - marketing@pyronics.be

ESA India

Plot No. J-17, MIDC, Bhosari, Pune, 411 026, India
tel. +91.(020).68197001 - esaindia@esapyronics.com

www.esapyronics.com