

DUAL FUEL BURNERS

XDF SERIES

FEATURES

- Mixer body: cast iron G25
- Plate: cast iron G25
- Pre-heated air: up to 450°C
- Oil operating capacity: 100 to 1650 kW
- Gas operating capacity: 90 to 1450 kW
- Gas and air pressure at burner: 70÷100 mbar
- Adequate to different types of gas: CH₄/L.P./propane/etc.
- Adequate to different types of light oils: viscosity up to 3°E
- Gas operating turndown range: 10÷1
- Oil operating turndown range: 6÷1
- Excellent flame stability with: excess air
excess fuel
on ratio firing
- Patented atomization.
- Low NO_x level.
- Separated air and gas inlets, mixing at discharge point, no flashback.



F361001

APPLICATIONS

- Ceramic baking furnaces.
- Sanitary fittings baking furnaces.
- Forges.
- Annealing furnaces.
- Heating furnaces.
- Melting furnaces.
- Driers.
- Incinerators.
- Metallic, resin and polymer treating furnaces.
- Hot air generators.



F361002

DESCRIPTION

The XDF dual fuel burners are nozzle mixing oil or gas units designed for on ratio or large excess of air firing. The unique stepped tunnel design produces excellent flame stability at all firing rates.

INSTALLATION

XDF single tunnel, dual fuel burners are usually mounted on the wall. Other mounting positions are not recommended; specify if other mounting positions are absolutely necessary when you order it. The furnace refractory should be set to leave some room on all sides of the block. This space should be packed with flexible, refractory, ceramic fiber protected by 20 mm of refractory concrete on all sides

to allow for expansion of the walls (see technical note). Flexible connectors are recommended for air and gas connections at the burner to allow slight movement or misalignment of piping and are required when pre-heated air is involved. Air and gas connections are Pyronics' standard threaded, or welding flanged type. They may rotate by 90°.

IGNITION AND FLAME DETECTION

XDF single tunnel, dual fuel burners must be ignited at low fire by blast pilot, PBST. The pilot burner should be cut off after ignition of the main burner therefore flame detection must be carried out by UV-scanners placed in an anticlockwise position as compared to the

pilot burner. On request, a WAND or DSE electrode may be used for ignition of low capacity burners. In this case a UV-2 ultraviolet scanner must be used. Flame detection systems are required on all burners operating at furnace temperatures below 750°C.

Catalog No.	Pilot burner ignition		Electrode ignition	
	Ignition	Detection	Ignition	Detection
12XDF	P64PBST	UV-2 / 6EN-150 *	(on request)	(on request)
16XDF	P64PBST	UV-2 / 6EN-150 *	(on request)	(on request)
24XDF	P86PBST	UV-2 / 6EN-300 *	(on request)	(on request)
32XDF	P86PBST	UV-2 / 6EN-300 *	(not available)	(not available)
48XDF	P86PBST	UV-2 / 6EN-300 *	(not available)	(not available)

(*) In most cases, we suggest you to make flame detection through UV- scanner. In some particular cases, it is possible to use continue pilot burner with detection electrode.

CAPACITY TABLE

Catalog No.	70 mbar air pressure drop				100 mbar air pressure drop				Flame lenght (oil) mm
	Atomizing air flow Nm ³ /h	Combustion air flow Nm ³ /h	Oil capacity kW (¹)	Gas capacity kW	Atomizing air flow Nm ³ /h	Combustion air flow Nm ³ /h	Oil capacity kW (²)	Gas capacity kW	
12 XDF	10	90	102	92	12	108	122	109	300 ÷ 500
16 XDF	20	180	203	183	24	216	243	219	500 ÷ 750
24 XDF	40	360	407	366	48	432	487	438	1000 ÷ 1250
32 XDF	80	720	814	733	96	864	973	876	1250 ÷ 1500
48 XDF	160	1440	1628	1465	192	1728	1946	1751	2000 ÷ 2500

NOTE:

Flame dimensions are approximate, referred to burners feeded with oil, working at stoichiometric ratio, in free air. Values are included in a range: minimum value is referred to burner working at nominal capacity (¹), higher value at maximum capacity (²).

Flame dimensions referred to burners feeded with CH₄ are equal to equivalent (same capacity) NM burners (see bulletin E3501).

FLOW CHART

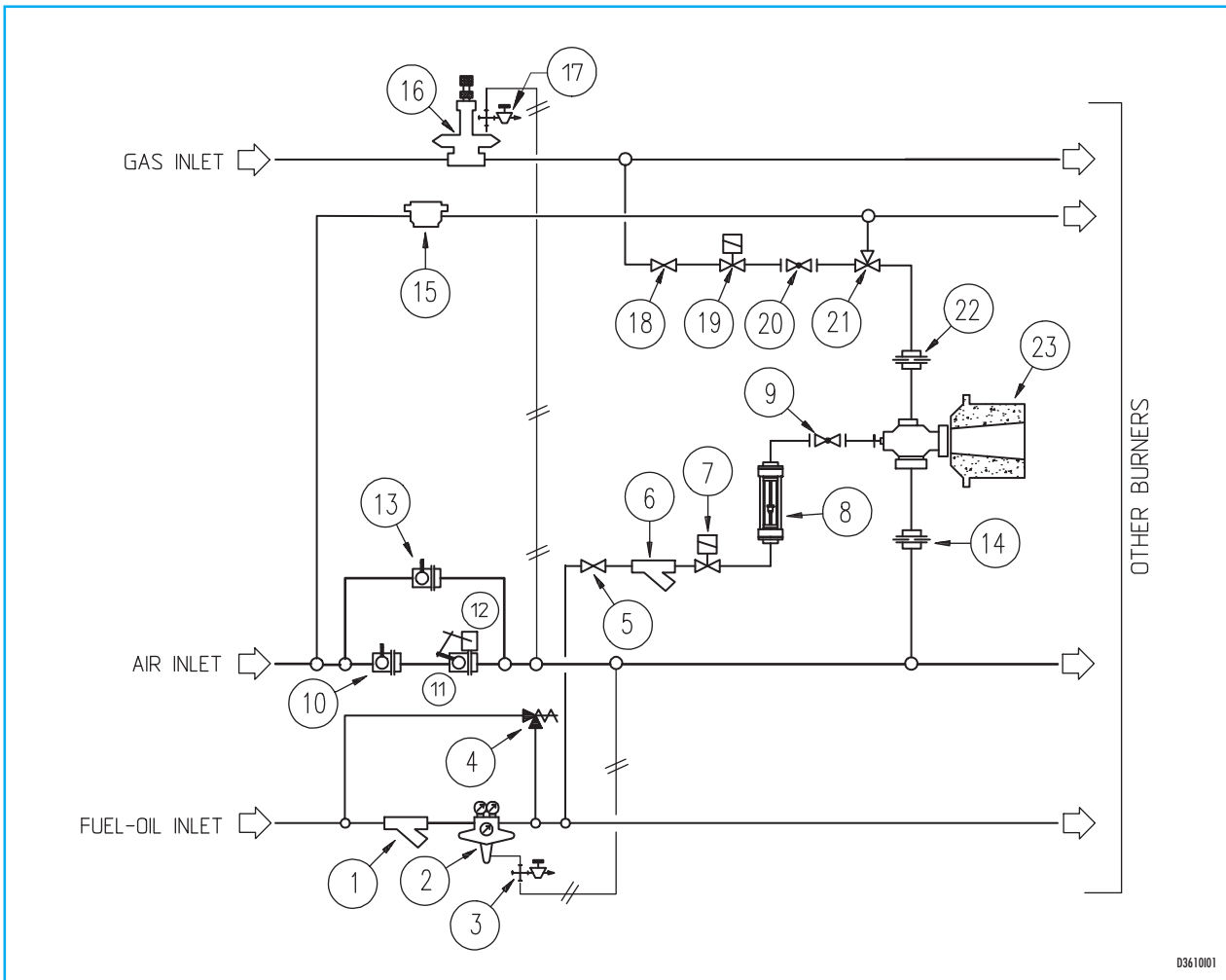

D361001

Pos.	Model identification	Pos.	Model identification
1	Fuel-oil filter	13	Air butterfly valve
2	Fuel-oil flow regulator	14	Orifice flow meter for ΔP air at each burner
3	Impulse line	15	Atomization air filter
4	Safety valve	16	Balanced zero regulator
5	Fuel-oil ball valve	17	Impulse line
6	Fuel-oil filter at each burner	18	Gas ball valve at each valve
7	Fuel-oil safety solenoid valve at each burner	19	Safety solenoid gas valve at each burner
8	Flowmeter	20	Gas adjuster
9	Fuel-oil micrometer valve	21	Three-way gas valve / atomization air valve
10	Manual air valve	22	Orifice flow meter
11	Motorized air valve	23	Dual fuel burner
12	Electric control		

DIMENSIONS

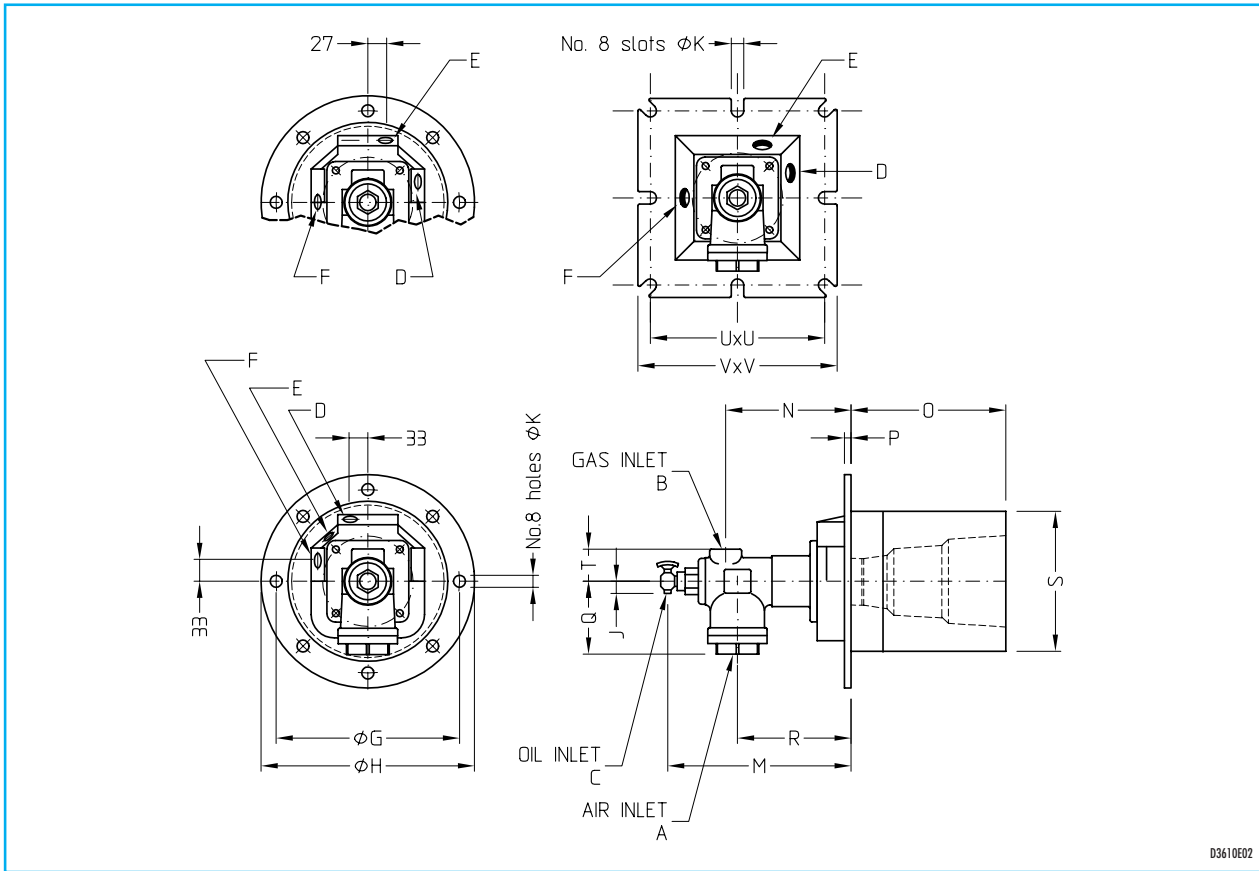

D3610E02

Catalog no.	ø A	ø B	ø C	ø D	ø E	ø F
12 XDF	1.1/2"	3/4"	1/8"	3/4"	3/4"	3/4"
16 XDF	2"	1"	1/8"	3/4"	3/4"	3/4"
24 XDF	3"	1.1/2"	1/4"	3/4"	1"	3/4"
32 XDF	4"	2"	1/4"	3/4"	1"	3/4"
48 XDF	6"	3"	1/4"	3/4"	1"	3/4"

Catalog no.	G mm	H mm	J mm	K mm	M mm	N mm	O mm	P mm	Q mm	R mm	S mm	T mm	U mm	V mm
12 XDF-R	—	—	16	14	321	203	230	10	79	121	178 ø	29	213 □	254 □
12 XDF-S	—	—	16	14	321	203	230	10	79	121	178 □	29	213 □	254 □
16 XDF-R	289 ø	330 ø	16	16	286	191	254	13	102	162	203 ø	60	—	—
16 XDF-S	—	—	16	16	308	206	254	13	102	184	229 □	60	278 □	330 □
24 XDF-R	349 ø	406 ø	25	16	387	264	305	13	140	241	298 ø	60	—	—
32 XDF-R	349 ø	406 ø	25	16	384	260	305	13	143	238	298 ø	80	—	—
48 XDF-R	457 ø	508 ø	25	16	438	295	330	13	194	257	400 ø	114	—	—

ø: Model with round refractory block

□: Model with square refractory block

ORDERING CODES - BURNER

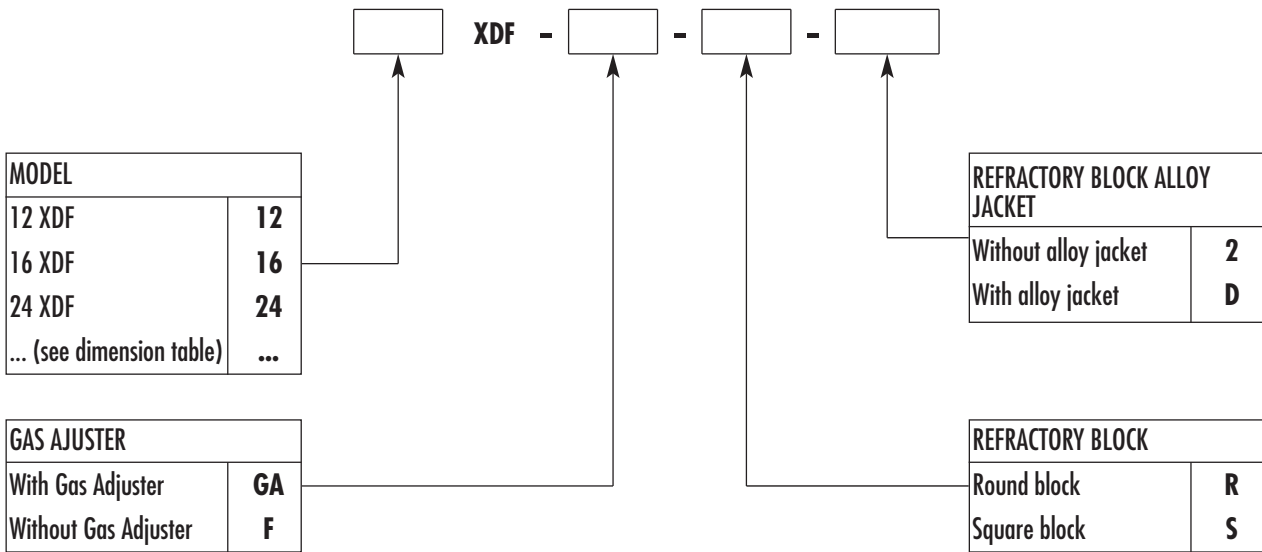

ORDERING CODES - REFRACTORY BLOCK ONLY

